

DESCRIPTION

Equipped with an attenuator, the TOA BS-677BT is a full-range speaker system with frequency response of 100-10,000 Hz. Its rated input is 6 W.

SPECIFICATIONS

Input	Rated 6 W
Impedance	1.7 kΩ
Sound Pressure Level	330 Hz~3,300 Hz, 91 dB (1 m, 1 W) Pink noise input
Frequency Response	100 Hz~10,000 Hz (-20 dB from peak of SPL)
Attenuation	OFF (NC), 1 (-12 dB), 2 (-6 dB), 3 (0 dB)
Speaker Component	12 (4.72") cm dynamic cone-type speaker
Finish	Enclosure : Vinyl chloride particle board, Black
Dimensions(W×H×D)	200 (7.87")×250 (9.84")×100 (3.94") mm
Weight	1.4 kg (3.09 lb.)
Accessories	Tapping screw 4×35.....2

APPEARANCE

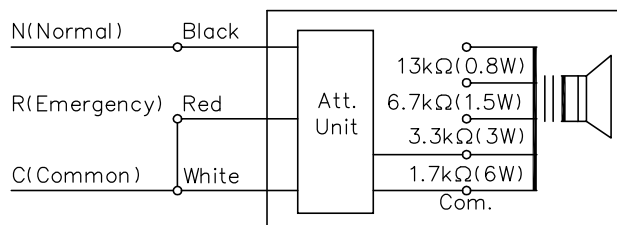
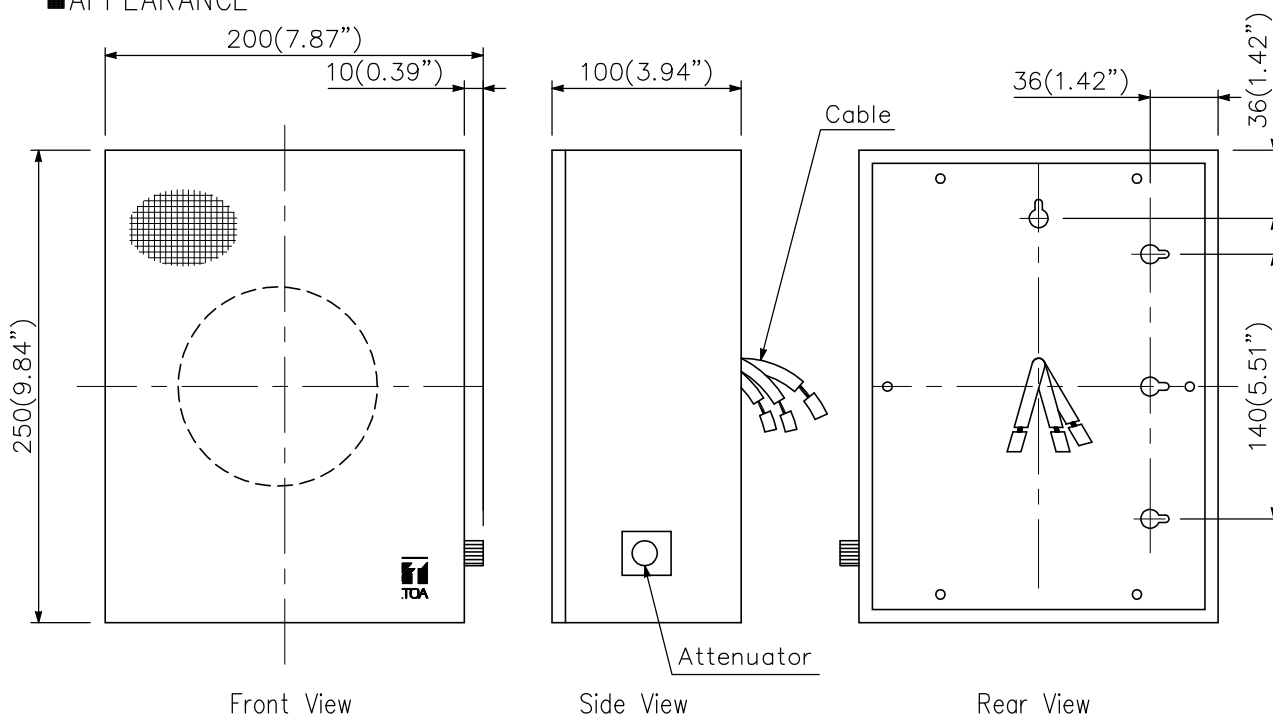

2-wire system

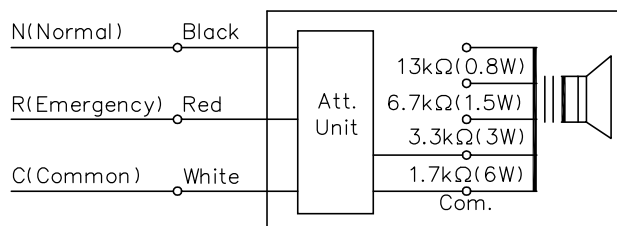

3-wire system

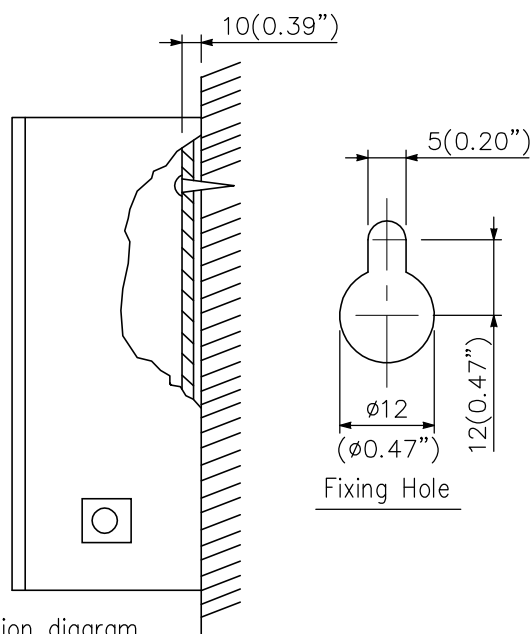

Installation diagram

UNIT:mm SCALE:1/4