

## ■ SPECIFICATIONS

Rated Input	6 W (70 V and 100 V Line)
Impedance	Factory-preset: 1.7 kΩ Avoid impedance setting of 830 Ω when the line voltage is 100 V, as this will cause damage to the speaker. 100 V line: 1.7 kΩ (6 W), 3.3 kΩ (3 W), 6.7 kΩ (1.5 W) 70 V line: 830 Ω (6 W), 1.7 kΩ (3 W), 3.3 kΩ (1.5 W), 6.7 kΩ (0.8 W)
Output SPL	87 dB (1 W, 1 m)
Frequency Response	150 – 10,000 Hz
Line Voltage	70 V and 100 V Line
Internal Speaker	12 cm dynamic speaker
Weight	1.2 kg
Finish	Case: ABS resin, black
Accessories	Ceiling cover (white).....1, Ceiling bracket .....1, Suspension bracket .....1, Mounting screw (white).....2, Tapping screw 4 .....2, ※Machine screw M4 .....2, ※Machine screw M3 .....2 (※ISO metric screw thread)

## ■ APPEARANCE

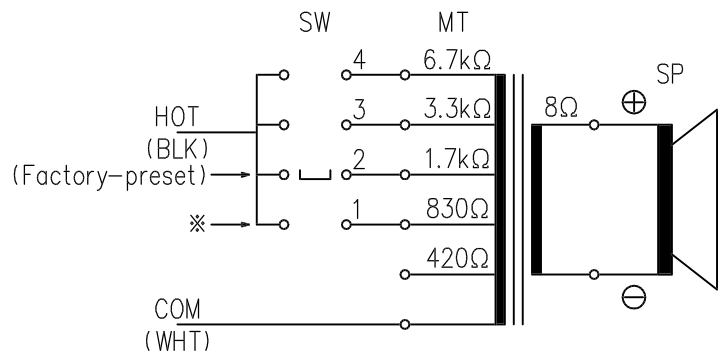
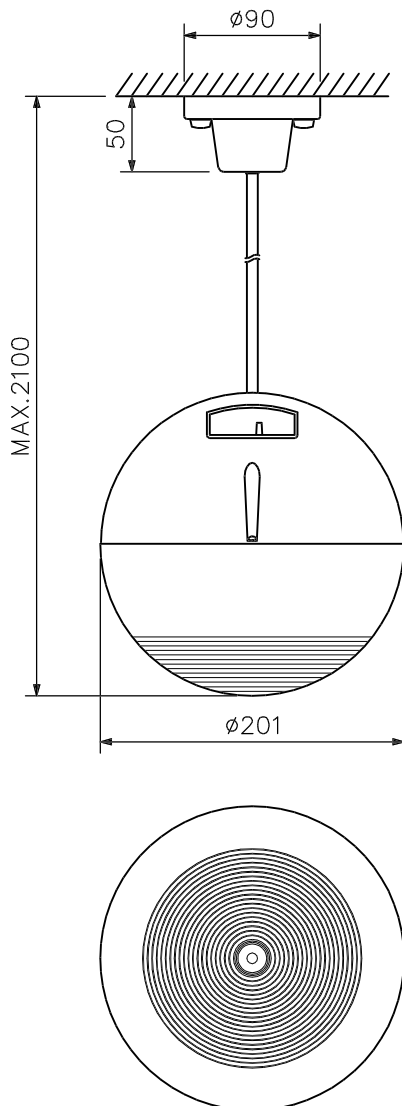

※ When operating the speaker on 100 V line, do not set the impedance selection switch to this position.

DIAGRAM

UNIT:mm SCALE:1/5