

# CS-810/830



## COLUMN SPEAKER(OUTDOOR USE)



CS-810

CS-830

### FEATURES

- **OUTDOOR USE**  
These column speakers are designed for outdoor use.
- **LONG LIFE**  
You can use these long time, why these are designed with aluminum alloy and painted for anti-rust.
- **HIGH EFFICIENCY FOR P.A.**  
Full range speaker unit and matching transformer are incorporated for high efficiency of P.A.
- **EASY INSTALLATION**  
With instrument, you can install it easily by using provided bracket.
- **2 WAY SYSTEM**  
To assure absolute long-term reliability, these model are used by tweeter of high quality.

### SPECIFICATION

- **ELECTRICAL** \*0dB=0.775Vrms
  - CS-810
    - Rated Input .....10W
    - Impedance.....1k $\Omega$ /2k $\Omega$
    - Frequency Response .....200Hz-22kHz
    - SPL(1m/W) .....92dB
  - CS-830
    - Rated Input .....30W
    - Impedance.....330 $\Omega$ /660 $\Omega$
    - Frequency Response .....200Hz-22kHz
    - SPL(1m/W) .....96dB
  - Material of Case.....Aluminum
- **GENERAL**
  - Weight.....CS-810:2.9kg  
CS-830:4.7kg
  - Dimensions .....CS-810:149(W) × 310(H) × 124(D)mm  
CS-830:149(W) × 530(H) × 124(D)mm

# MOUNTING METHOD

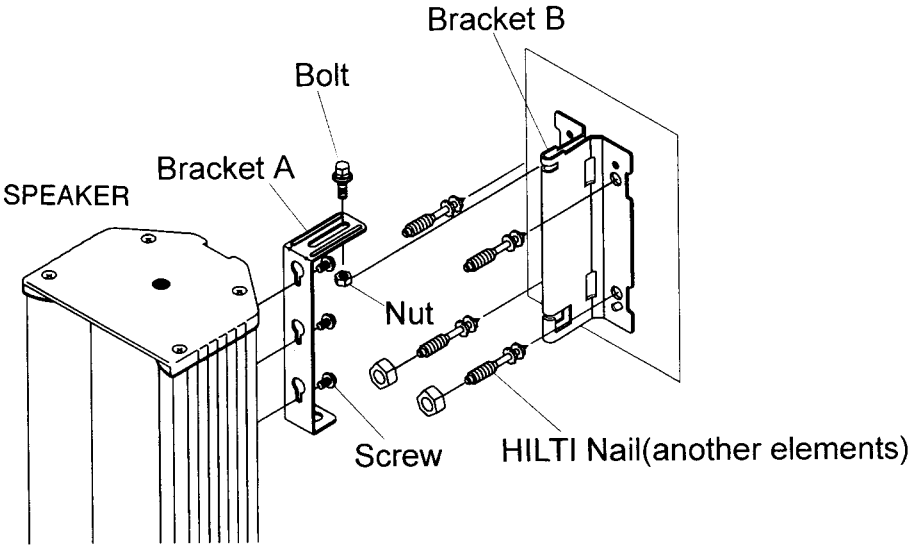

# TERMINAL CONNECTION

