

## COLUMN SPEAKER(OUTDOOR USE)



### FEATURES

- **OUTDOOR USE**  
These column speakers are designed for outdoor use.
- **LONG LIFE**  
You can use these long time, why these are designed with aluminum alloy and painted for anti-rust.
- **HIGH EFFICIENCY FOR P.A.**  
Full range speaker unit and matching transformer are incorporated for high efficiency of P.A.
- **EASY INSTALLATION**  
With instrument, you can install it easily by using provided bracket.
- **2 WAY SYSTEM**  
To assure absolute long-term reliability, these model are used by tweeter of high quality.

### SPECIFICATION

- **ELECTRICAL** \*0dB=0.775Vrms
  - Rated input .....20W
  - Impedance ..... 500Ω/1kΩ
  - Frequency response .....200Hz-22kHz
  - SPL(1W/1m) .....96dB
- **GENERAL**
  - Material of case.....Aluminum
  - Weight .....3.6kg
  - Dimensions .....149(W) × 420(H) × 124(D)mm

# MOUNTING METHOD

---

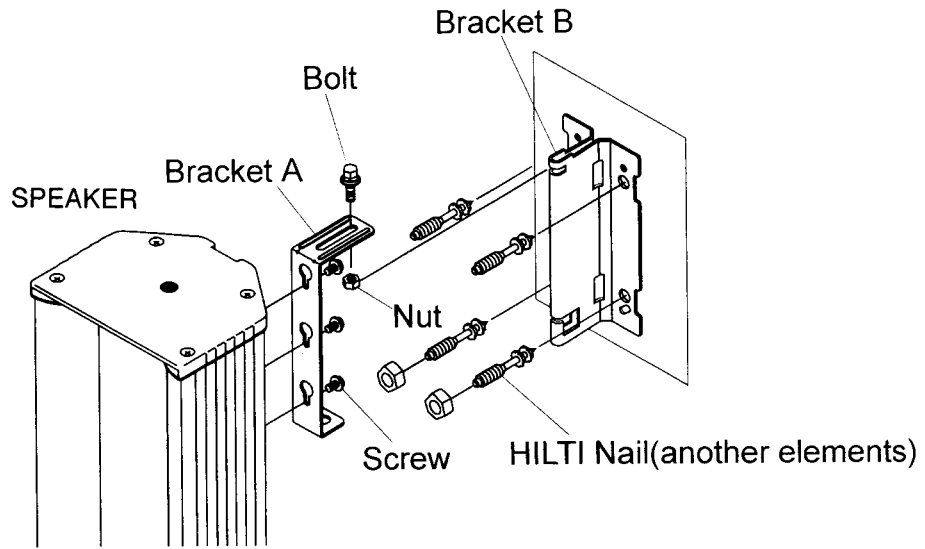

# DUAL CHANNEL ANALYZER GRAPHICS

