

CS-910/920/930/940

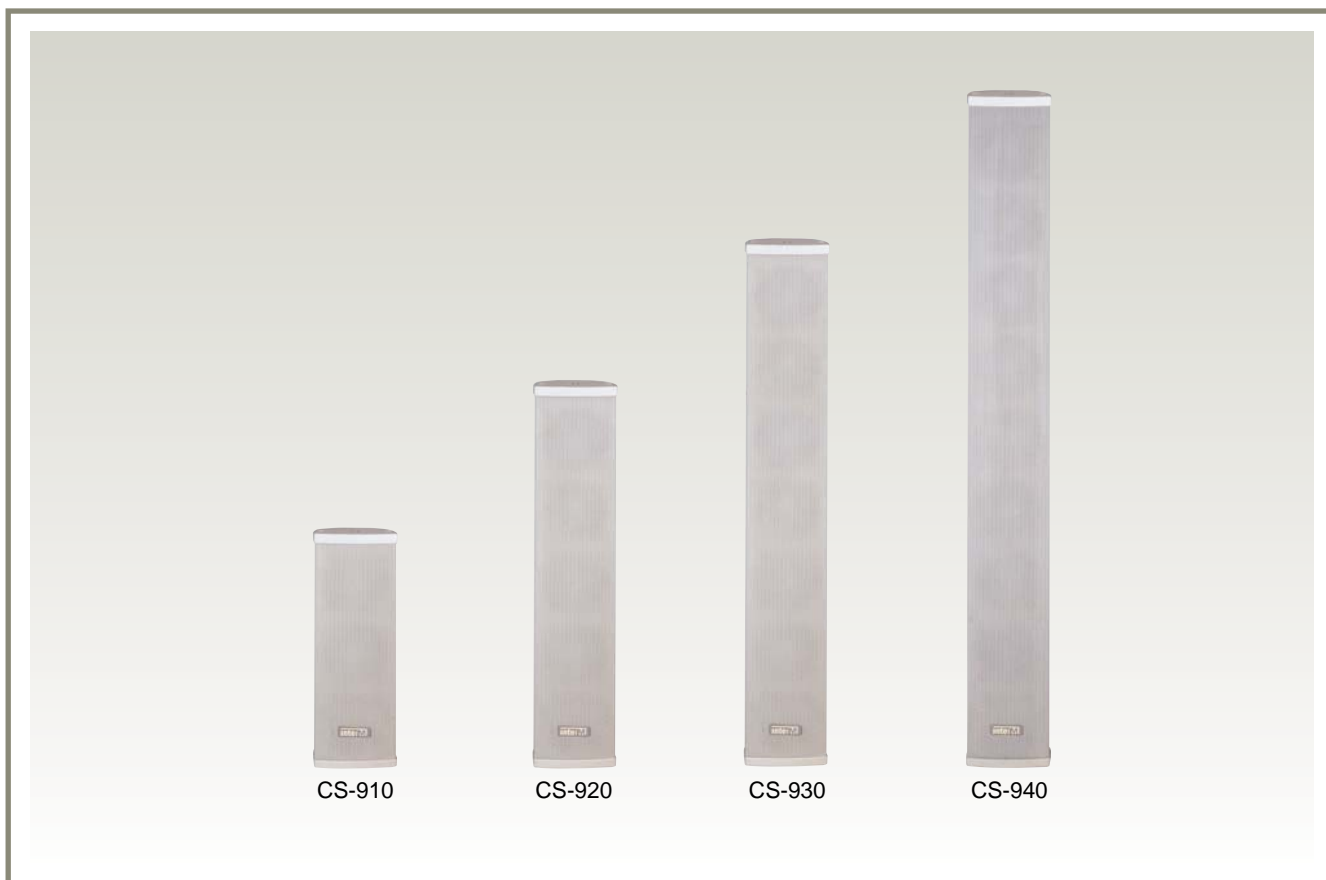

COLUMN SPEAKER(INDOOR USE)



CS-910

CS-920

CS-930

CS-940

FEATURES

- **INDOOR USE**
These column speakers are designed for indoor use.
- **LONG LIFE**
You can use these long time, why these are designed with aluminum alloy and painted for anti-rust.
- **HIGH EFFICIENCY FOR P.A.**
Full range speaker unit and matching transformer are incorporated for high efficiency of P.A.
- **EASY INSTALLATION**
With instrument, you can install it easily by using provided bracket.

SPECIFICATIONS

■ ELECTRICAL

	CS-910	CS-920	CS-930	CS-940
Rated Input	10W	20W	30W	40W
Impedance	1kΩ/2kΩ	500Ω/1kΩ	330Ω/660Ω	250Ω/500Ω
Frequency Response	250Hz~14kHz			
SPL (1m/W)	88dB	90dB	91dB	93dB
Material of case	Aluminum			

■ GENERAL

- WeightCS-910:1.4kg
CS-920:2.5kg
CS-930:3.6kg
CS-940:4.7kg
- DimensionsCS-910:104(W) × 300(H) × 86(D)mm
CS-920:104(W) × 478(H) × 86(D)mm
CS-930:104(W) × 656(H) × 86(D)mm
CS-940:104(W) × 834(H) × 86(D)mm

MOUNTING METHOD

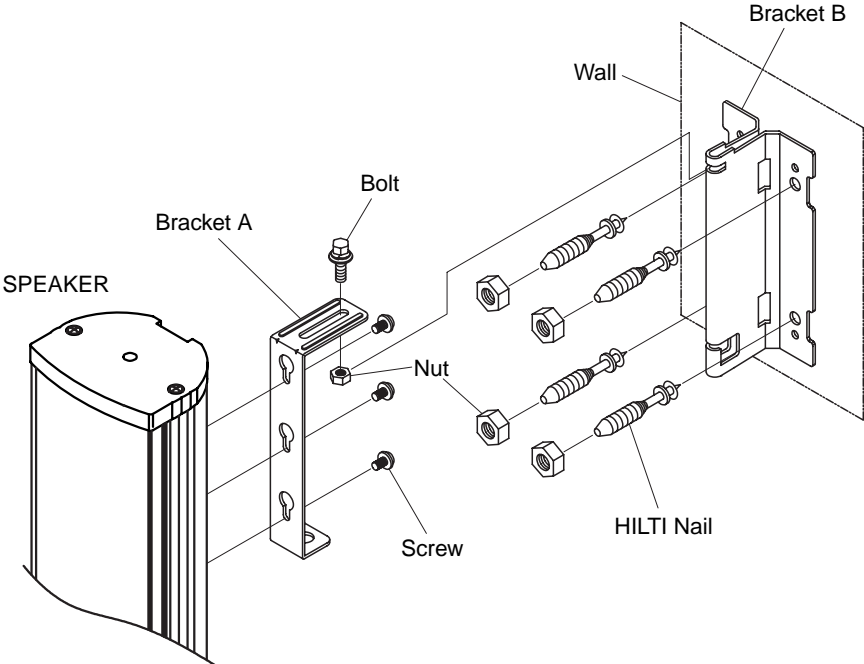

TERMINAL CONNECTION

